

DPR3000

TWO PASS DOUGH ROLLER

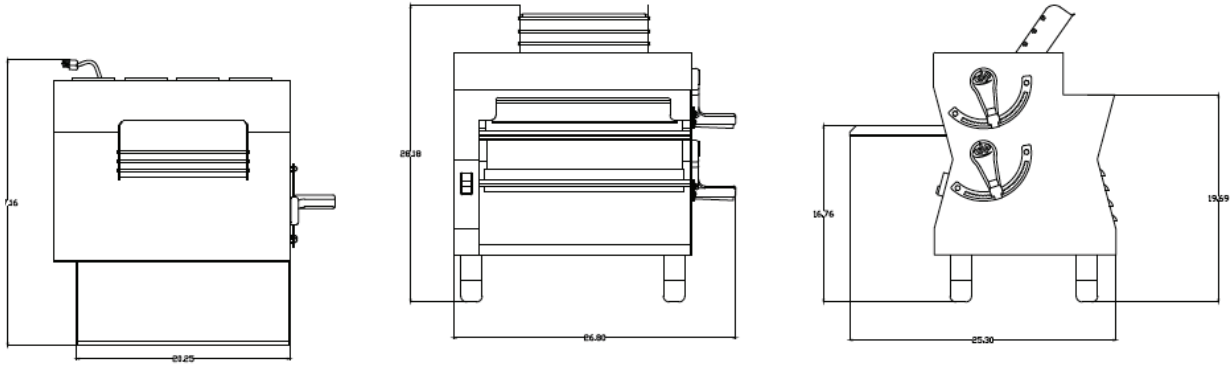

TOP VIEW

FRONT VIEW

SIDE VIEW

Equipment Details

Bearings	Sealed	Rollers	Stainless
Motor	3/4 Hp	Shipping Weight	219lbs/99kg
Finish	Stainless	Machine Weight	180lbs/81kg
Thickness Control	Yes	Voltage	115/240
ON/OFF Switch	Yes	Amps	8.80/4.40
Power Cord Length	72"	NEMA Plug	5-15P/6-15P



PROLUXE™

CORPORATE HEADQUARTERS
20281 HARVILL AVE. PERRIS, CA 92570

HELPING COMMERCIAL KITCHENS
PRODUCE GREAT FOOD FASTER

ADVICE AND SUPPORT
1-800-624-6717

PROLUXE™

PROLUXE.COM

Reduce Prep Time

This versatile unit is perfect for sheeting all types of dough including pie crusts, tortillas, pizza dough, pitas, and more. This counter-top dough roller features a dual pass design for fewer runs through the machine and a consistent product.



DPR3000

Two Pass Dough Roller



More Efficient

A single operator can roll out up to 250 pieces per hour. A simple "on/off" provides easy operation, and rubber non-skid legs ensure the unit stays securely in place during use.



250+ PRODUCTS PER HOUR



THICKNESS CONTROL - 1/16" TO 5/8"



HIGH PRODUCTION



PRODUCT VERSATILITY